

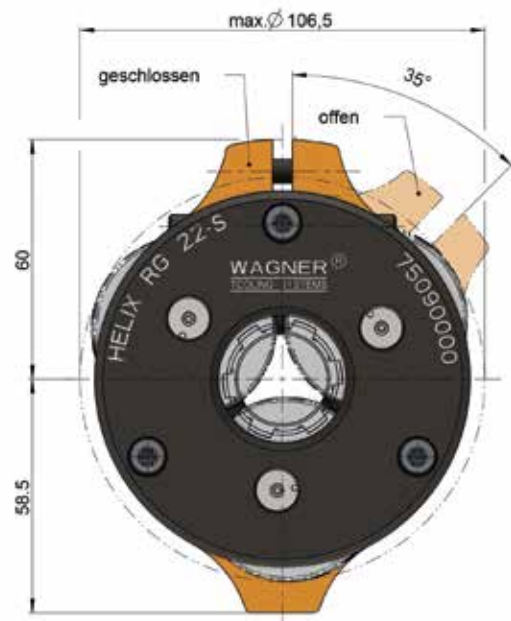

stillstehend

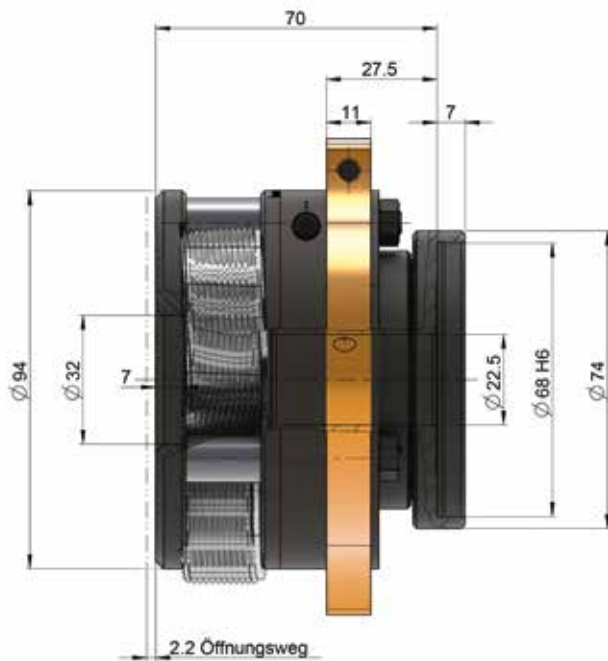

Axial-Rollsystem HELIX RG22-S/FG22-S

Gewicht Werkzeug mit Rollen	2,6 kg
Gewicht Schaft	0,3–1 kg

Optionale Werkzeugausstattung

- Schließeinrichtung

Schaft-Ø D mm (Zoll)	d mm	L mm	L _s mm	L ₁ mm	L ₂ mm	L ₃ mm	G
19,05 (3/4")	12,5	49	42	7,2	–	–	M14-LH
20	12,5	49	42	7,2	–	–	M14-LH
22	12,5	49	42	7,2	–	–	M14-LH
25	16,5	55	48	7,2	–	–	M20 × 1,5
25,4 (1")	16,5	55	48	7,2	–	–	M20 × 1,5
30	22,5	67	55	7,2	–	52	M18 × 1,5
32	16,5	87	80	7,2	–	52	M18 × 1,5
VDI20	16,5	59,7	40	19,7	8	16	–
VDI30	16,5	78	55	23	8	69	–
VDI40	25	86	63	23	16	71	–

Abbildung: Schaftmaße, siehe Tabelle

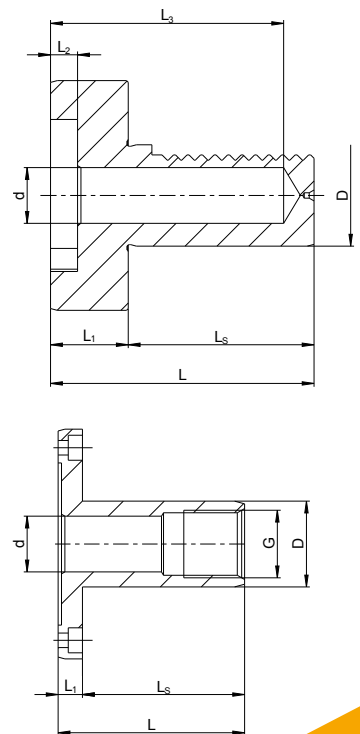



HELIX Axial-Rollsystem RG22-R/FG22-R

umlaufend

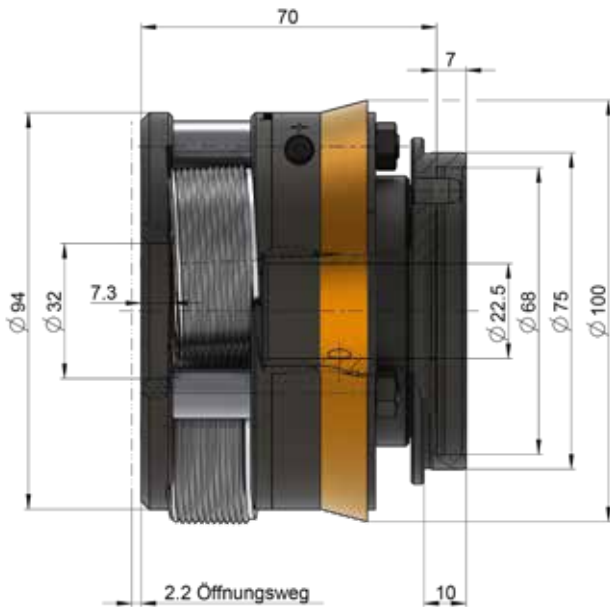

Axial-Rollsystem HELIX RG22-R/FG22-R

Gewicht Werkzeug mit Rollen	2,6 kg
Gewicht Schaft	0,3–1 kg

Optionale Werkzeugausstattung

- Schließeinrichtung

Schaft-Ø D mm (Zoll)	d mm	L mm	L _s mm	L ₁ mm	L ₂ mm	L ₃ mm	G
19,05 (3/4")	12,5	49	42	7,2	–	–	M14-LH
20	12,5	49	42	7,2	–	–	M14-LH
22	12,5	49	42	7,2	–	–	M14-LH
25	16,5	55	48	7,2	–	–	M20 × 1,5
25,4 (1")	16,5	55	48	7,2	–	–	M20 × 1,5
30	22,5	67	55	7,2	–	52	M18 × 1,5
32	16,5	87	80	7,2	–	52	M18 × 1,5
VDI20	16,5	59,7	40	19,7	8	16	–
VDI30	16,5	78	55	23	8	69	–
VDI40	25	86	63	23	16	71	–

Abbildung: Schaftmaße, siehe Tabelle

